

SALES ENQUIRIES

702 662 2202
702 662 2203
702 662 2204
702 662 2205



SPS

ROOFINGS & STRUCTURES

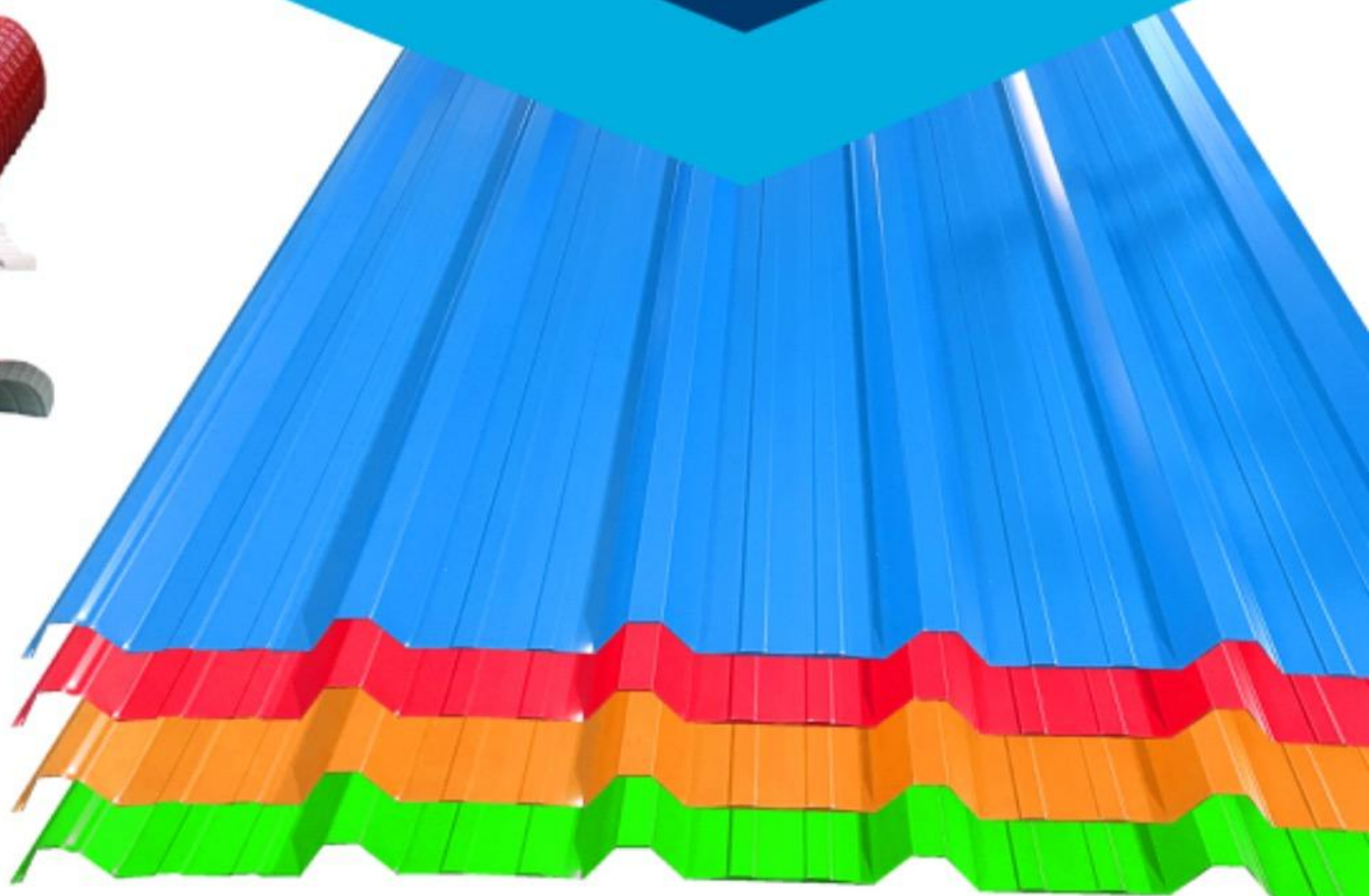

**COLOUR COATED METAL ROOF SHEET
ROOFING PRODUCTS
& ACCESSORIES**

✉ info@spsroofings.com
🌐 www.spsroofings.com

SCAN ME



FACTORY: 9/2, ARIYANAPALLI VILLAGE,
VEPPANPALLI POST,
KRISHANGIRI TAMILNADU - 635121

GODOWN : #78 6TH MAIN ROAD,
7TH CROSS, AMBEDKAR NAGAR,
WHITEFIELD BANGALORE 67



SPS

ROOFINGS & STRUCTURES



PPGI (Pre Painted Galvanised Sheets)

PPGI & PPGL sheets which are made up of world class raw material complying to international standards. Because of its excellent corrosion resistance, these sheets have become the most preferred material for various construction purposes, particularly roofing and walling.

Material Specifications

Pre-Painted Galvanized Steel Sheets (GI-Base)

Zinc coating	: Z 100 / 90 / 70 GSM
Primer service coat	: 5 microns epoxy/PU on both sides
Paint coating	: Regular Modified Polyester (RMP) (Optional - Silicon Modified Polyester & PVF 2)
Painting thickness (top)	: 18 - 20 microns
Painting thickness (bottom)	: 5- 7 microns
Surface paint reflection	: Semi Gloss / Matt Finish
Conforms to	: ASTM A653, A755, JISG3302, G3312, Is277, 513, 4246, AS 1397

Coated steel sheets is a unique building material that combines the strength of steel with excellent corrosion protection of Zinc or Zinc / Aluminium alloy coatings. It can be punched, pressed, roll-formed and joined into countless numbers of structural and decorative building products. The thickness ranges from 0.3 mm to 0.6 mm thick. They come in a standard width of 1060/1080 mm and maximum length of the sheet will be 12 meter. Colours available are Off White, Mist Green, Caulified Green, Brick Red, Pepsi (Royal) Blue, Taurus Blue & Sky Blue.

PPGL (Pre Painted Galvalume Sheets)

Pre-Painted Alu-Zinc Steel Sheets (Galvalume*)

(55% Aluminium 45% Zinc Alloy)

Alu-Zinc coating	: AZ 150 (Optional AZ 70)
Primer service coat	: 5 microns epoxy/PU on both sides
Paint coating	: Regular Modified Polyester (RMP) (Optional - Silicon Modified Polyester & PVF 2)
Painting thickness (top)	: 18 - 20 microns
Painting thickness (bottom)	: 5 - 7 microns
Surface paint reflection	: Semi Gloss / Matt finish
Conforms to	: ASTM A792, A755, JISG3321, G3322, AS 1397
Yield Strength	: 300 - 550 Mpa

BARE GALVALUME SHEETS

Quality bare galvalume roofing sheets have place an unprecedented demand among many construction leaders. Al-Zn alloy coated steel combination 55% aluminium, 43.5% Zinc, 1.5% Silicon.

Non-color Alu-Zinc Steel Sheets (Bare Galvalume*)
(55% Aluminium 45% Zinc Alloy)

Alu-Zinc coating	: AZ 150 (Optional AZ 70)
Conforms to	: ASTM A792, JIS G 3321, AS 1397
Yield Strength	: 300 - 550 Mpa

Material Dimensions

Technical Specifications

Total Coated Thickness (TCT)				
0.30mm, 0.35mm, 0.40mm, 0.45mm, 0.47mm, 0.50mm, 0.60mm				
Profile	Effective Width	Pitch (P)	Depth (D)	Sheet Width (SW)
Trapezoidal Roofing	1000 mm	200 mm	30 mm	1070 mm
	1000 mm	250 mm	32 mm	1070 mm

Variation ± 10mm

*Galvalume - Generic name

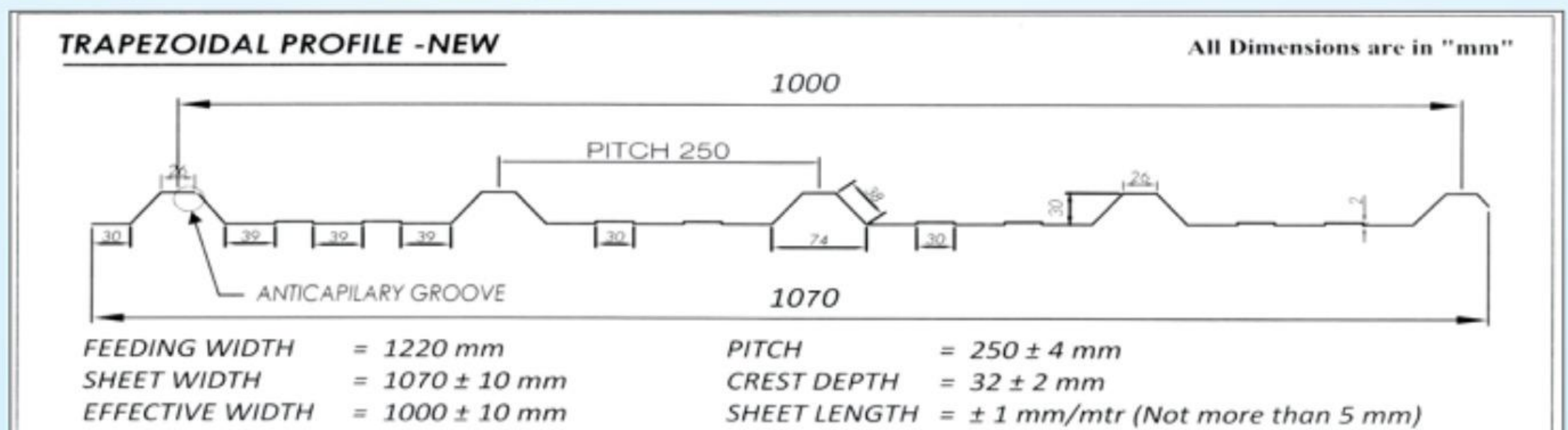
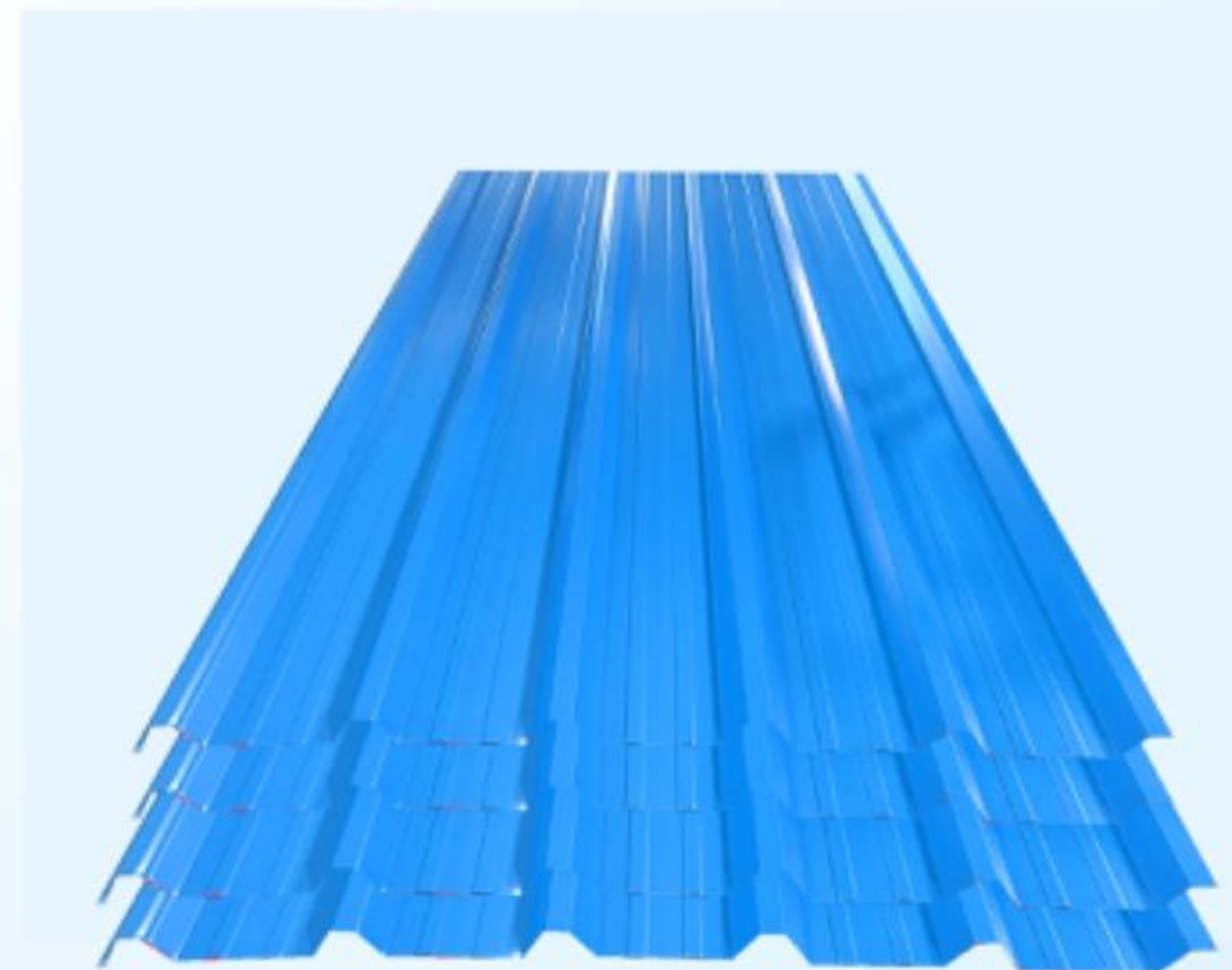

ONE STOP SOLUTION FOR
ALL YOUR ROOFING NEEDS...



SPS

ROOFINGS & STRUCTURES

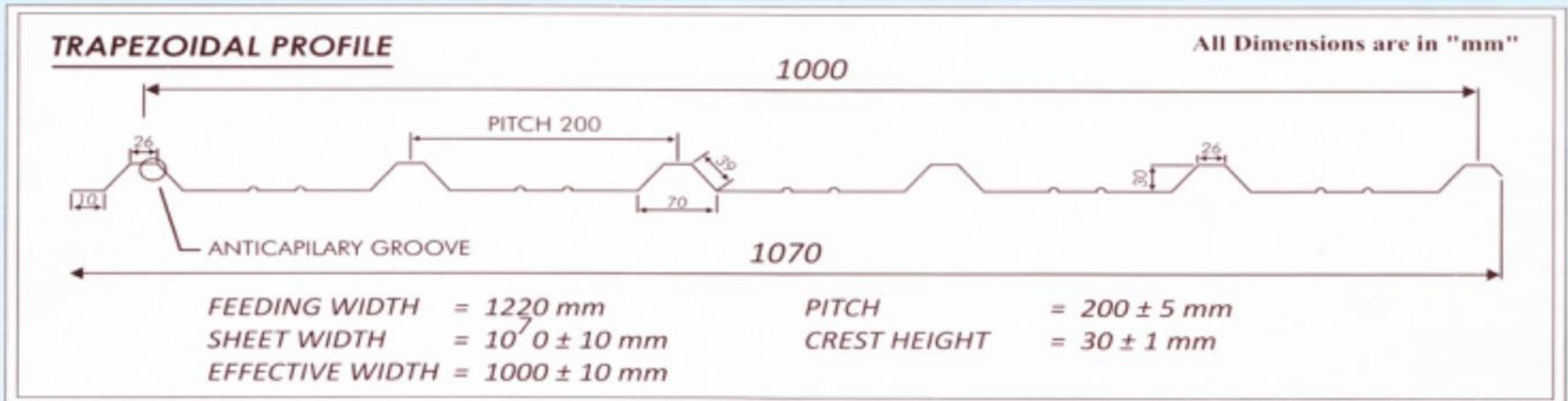
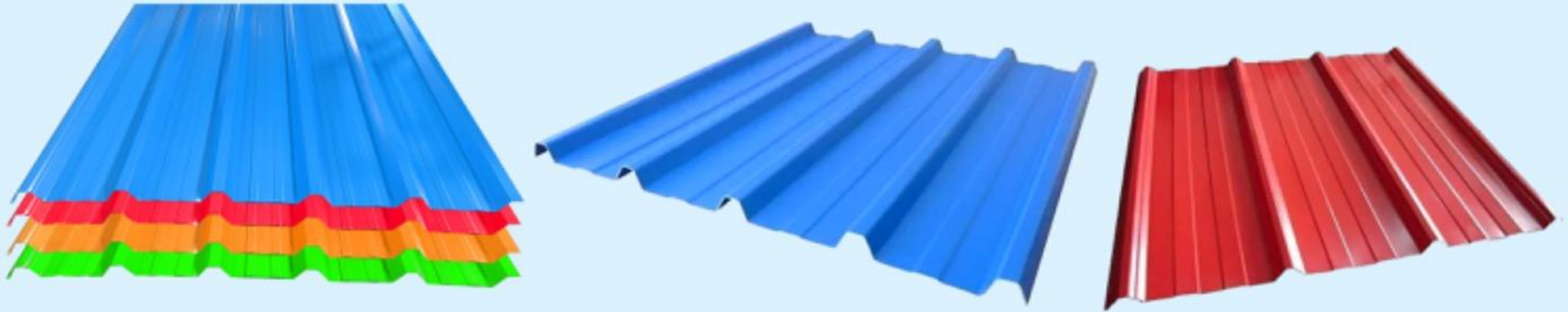

C & Z PURLINS

- Upto 40% savings in steel.
- Upto 30% savings in construction cost.
- Light Weight.
- Easy to Transport & handle.
- Supplied in exact length & pre-punched holes.
- Reduced fabrication cost.
- Ability to span long lengths.
- Close tolerances on sectional dimensions due to process of cold roll forming
- Fast erection
- No site drilling or cutting required.

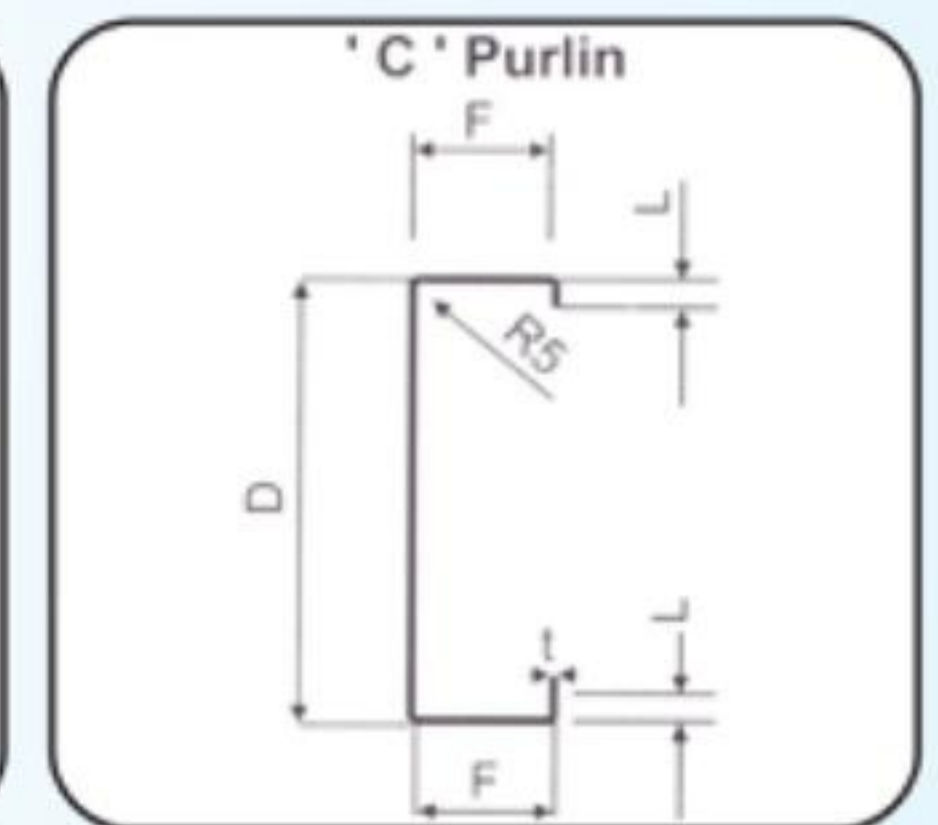
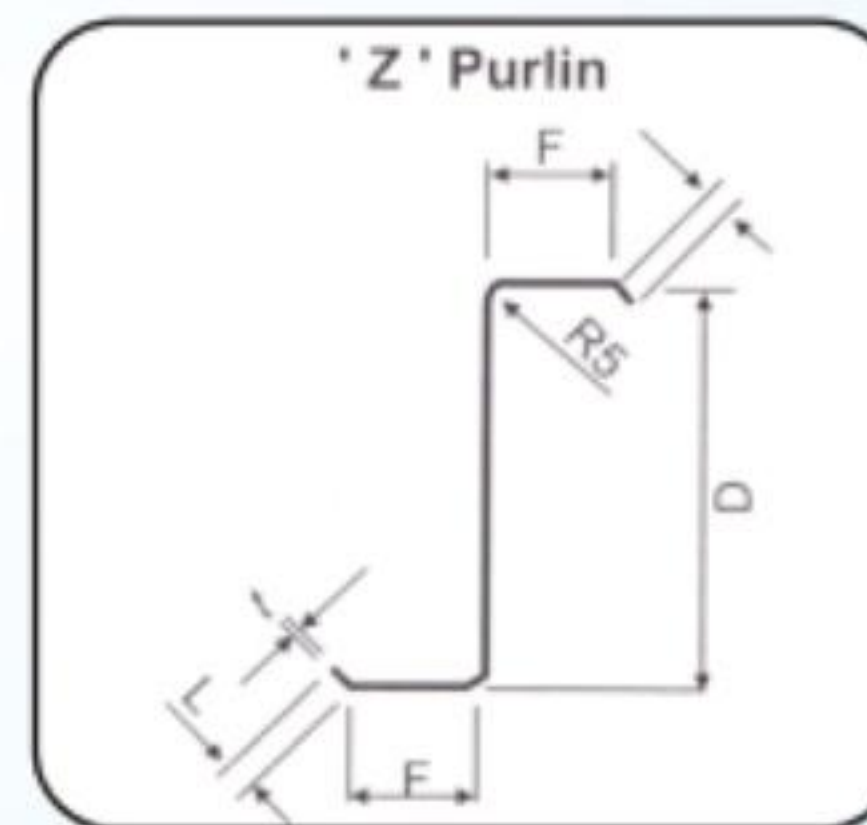

ROOF VENTILATORS

Available in Aluminum and stainless steel of different diameter. It is a self contained wind powered design to there are no operational costs incurred.

Advantages :

- Proper ventilation provides a cooler, low humidity work environment which reduces the need for costly air conditioning and industrial fans.
- Easy installation and reduced installation cost.



ONE STOP SOLUTION FOR
ALL YOUR ROOFING NEEDS...

SPS

ROOFINGS & STRUCTURES



ACCESSORIES FOR 1220 COIL - MEDIUM (ONLY 1000 mm EFFECTIVE WIDTH PROFILE)

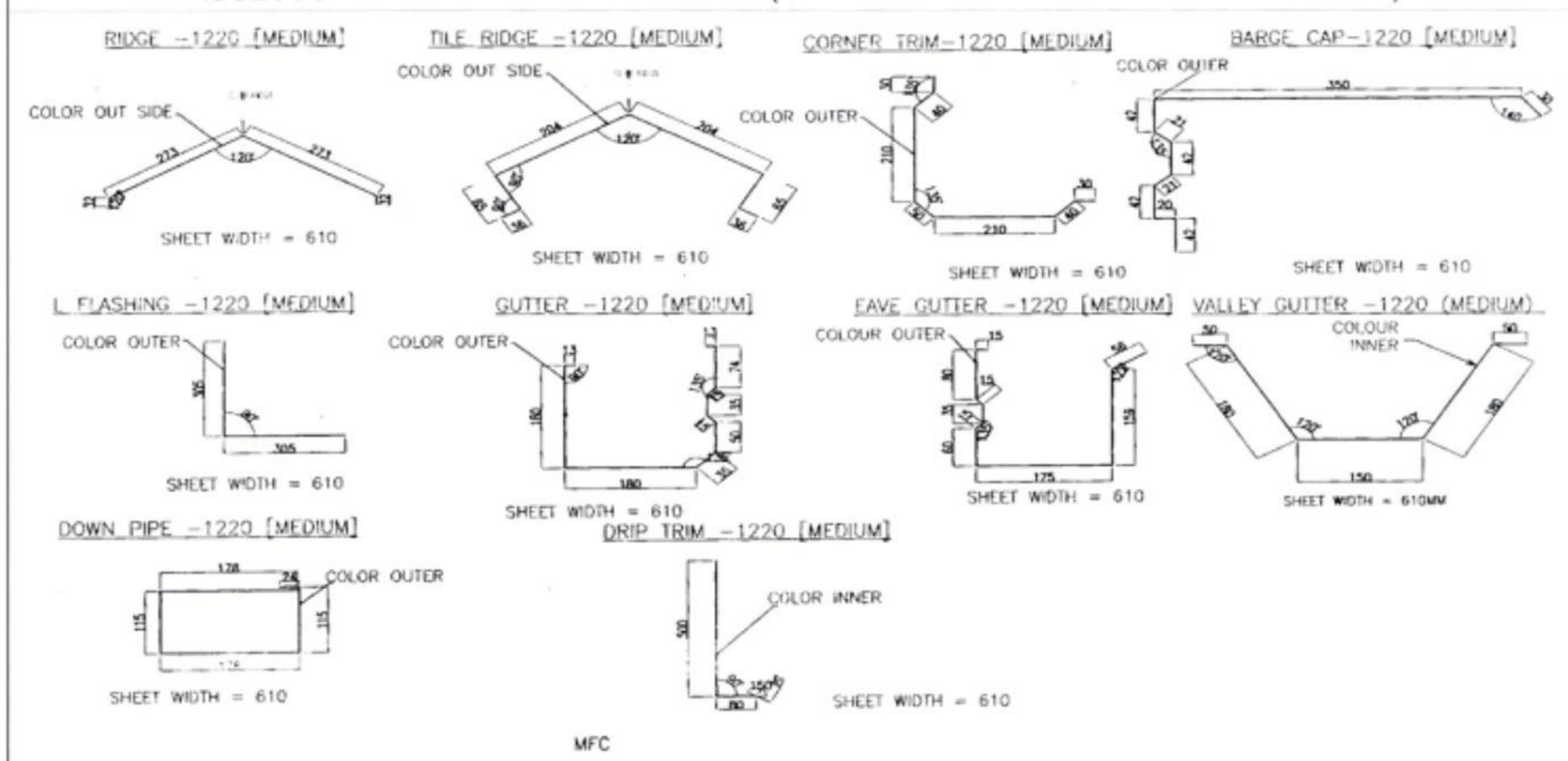

ACCESSORIES

- ➔ Flashings
- ➔ Down Take Pipe
- ➔ Screws with cops
- ➔ Louvers
- ➔ Gutters with clamps
- ➔ Sealant
- ➔ Ridges

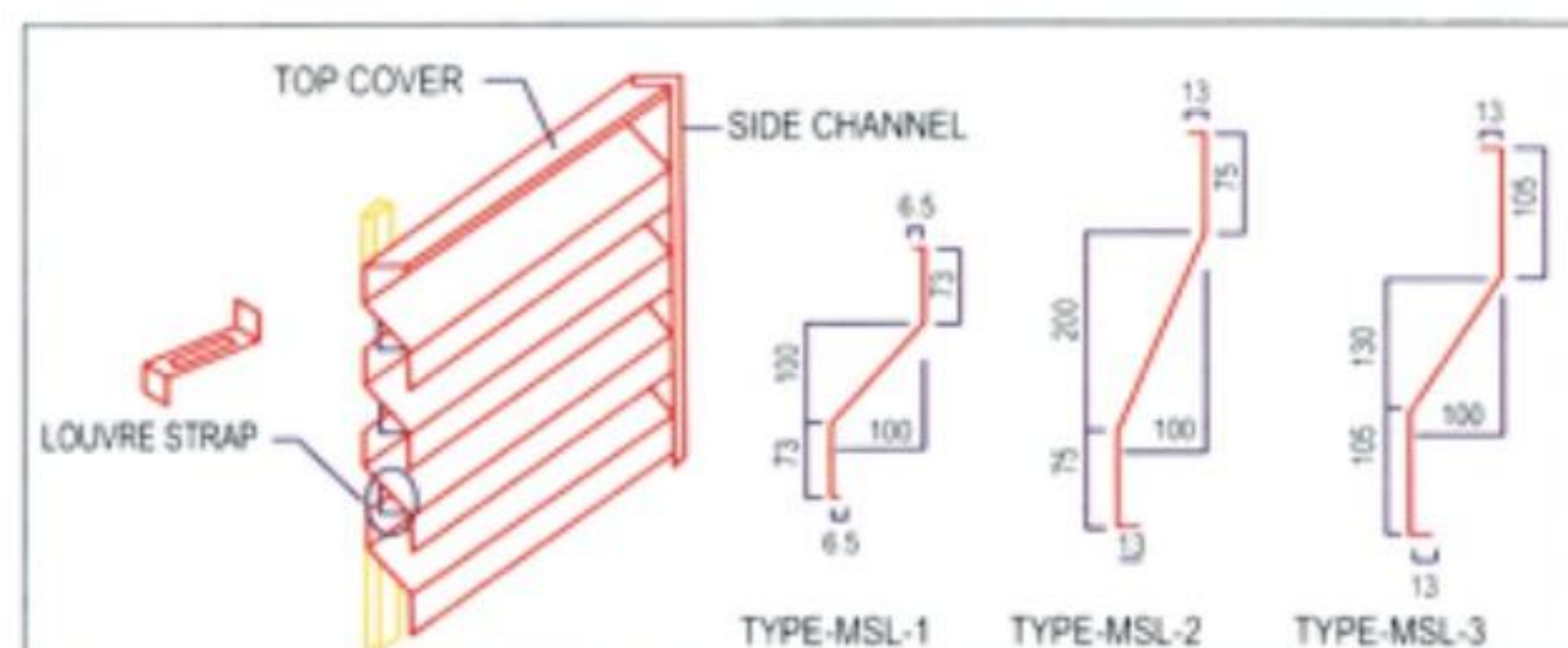

ONE STOP SOLUTION FOR
ALL YOUR ROOFING NEEDS...